

South Cambridgeshire Hall
Cambourne Business Park
Cambourne
Cambridge
CB23 6EA

t: 01954 713000
democratic.services@scambs.gov.uk
www.scambs.gov.uk

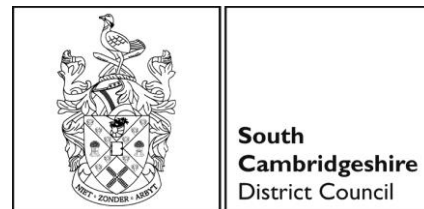

Friday 03 May 2024

To: Chair – Councillor Dr. Martin Cahn
Vice-Chair – Councillor Peter Fane
All Members of the Planning Committee - Councillors Ariel Cahn,
Bill Handley, Geoff Harvey, Dr. Tumi Hawkins, Dr Lisa Redrup,
Peter Sandford, Heather Williams, Dr. Richard Williams and Eileen Wilson

Quorum: 3

Substitutes Councillors Graham Cone, Sue Ellington, Bunty Waters,
if needed: Dr. Shrobona Bhattacharya, Anna Bradnam, Corinne Garvie,
Helene Leeming, William Jackson-Wood and Henry Batchelor

Dear Councillor

You are invited to attend the next meeting of **Planning Committee**, which will be held in the **Council Chamber, First Floor** on **Wednesday, 8 May 2024 at 10.00 a.m.** **A weblink to enable members of the press and public to listen to the proceedings will be published on the relevant page of the Council's website , normally, at least 24 hours before the meeting.**

Yours faithfully
Liz Watts
Chief Executive

Agenda

Plans Pack

Pages
3 - 12

Exclusion of Press and Public

The law allows Councils to consider a limited range of issues in private session without members of the Press and public being present. Typically, such issues relate to personal details, financial and business affairs, legal privilege and so on. In every case, the public interest in excluding the Press and Public from the meeting room must outweigh the public interest in having the information disclosed to them. The following statement will be proposed, seconded and voted upon.

"I propose that the Press and public be excluded from the meeting during the consideration of the following item number(s) in accordance with Section 100(A) (4) of the Local Government Act 1972 on the grounds that, if present, there would be disclosure to them of exempt information as defined in paragraph(s) of Part 1 of Schedule 12A of the Act."

If exempt (confidential) information has been provided as part of the agenda, the Press and public will not be able to view it. There will be an explanation on the website however as to why the information is exempt.

Notes

- (1) Some development control matters in this Agenda where the periods of consultation and representation may not have quite expired are reported to Committee to save time in the decision making process. Decisions on these applications will only be made at the end of the consultation periods after taking into account all material representations made within the full consultation period. The final decisions may be delegated to the Corporate Manager (Planning and Sustainable Communities).
- (2) The Council considers every planning application on its merits and in the context of national, regional and local planning policy. As part of the Council's customer service standards, Councillors and officers aim to put customers first, deliver outstanding service and provide easy access to services and information. At all times, we will treat customers with respect and will be polite, patient and honest. The Council is also committed to treat everyone fairly and justly, and to promote equality. This applies to all residents and customers, planning applicants and those people against whom the Council is taking, or proposing to take, planning enforcement action. More details can be found on the Council's website under 'Council and Democracy'.

The Council is committed to improving access to its agendas and minutes for all members of the community. We try to take all circumstances into account, but if you have any specific needs we will do what we can to help you. Please contact Democratic Services on 01954 713 000 or email democratic.services@scambs.gov.uk.

Further information for members of the public can be found at the below link.
[Link to further information for members of the public attending South Cambridgeshire District Council meetings.](#)

If you wish to ask a question or make a statement at a meeting, please refer to the Public Speaking Scheme at the below link.

[Link to the Public Speaking Scheme](#)

Further information for Councillors

[Declarations of Interest – Link to Declarations of Interest - Information for Councillors](#)

Councillors are reminded that Democratic Services must be advised of substitutions in advance of meetings. It is not possible to accept a substitute once the meeting has started.

Planning Committee



GREATER CAMBRIDGE
SHARED PLANNING

MINOR APPLICATIONS

24/00607/FUL

88-92 Station Road, Histon

Retention of the raising of chimney A to the required 1.8m height above the new ridge.

Officer recommendation: Approve

Site Location



Proposed Plans

Front elevation

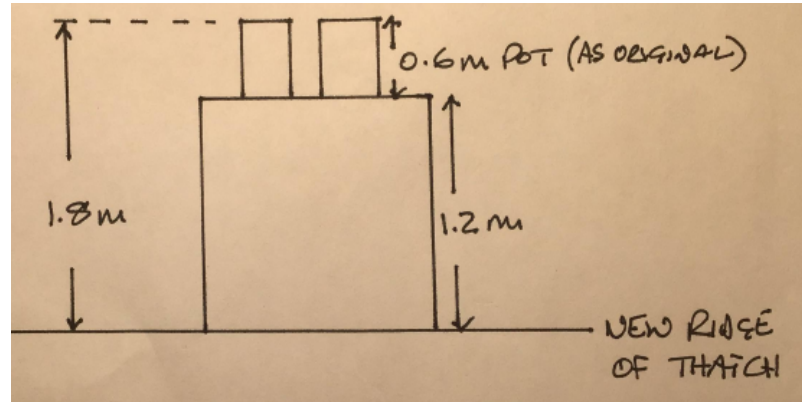

Page 7

Side elevation

88 STATION ROAD, HASTON
1/00607 / HFUL
2/2/24 J. M. M. M.

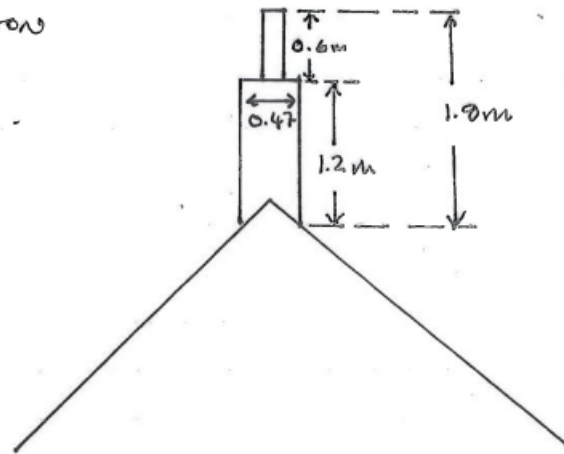

SIDE ELEVATION (1:50 SCALE) SHOWING NEW HEIGHT OF CHIMNEY BRICKWORK (SAME POT) IN LIKE FOR LIKE BRICKS + MORTAR TO ACHIEVE REQUIRED 1.8 m TOP OF POT TO THATCH. NO OTHER DIMENSIONS ALTERED.

Approval Planning Balance

Refusal

Material considerations

Material considerations

- Proposal will not cause harm to character and appearance of the area
- Proposal will not unduly impact upon residential amenity
- Proposal will not cause harm to the character of the Histon Conservation Area or the listed building



- None

Officer Recommendation: Approve

24/00608/LBC

88-92 Station Road, Histon

Retention of the raising of chimney A to the required 1.8m height above the new ridge.

Officer recommendation: Approve

Site Location

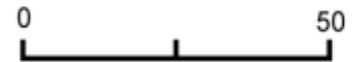

Proposed Plans

Front elevation

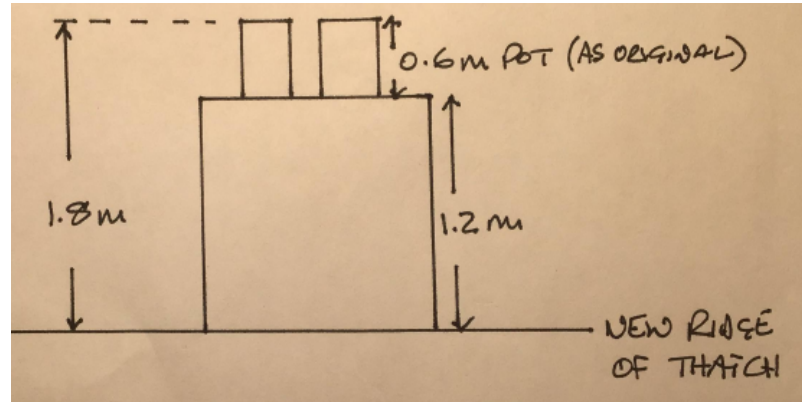

Page 11

Side elevation

88 STATION ROAD, HILSON
1/00607 / HFUL
2/2/24 J. M. M. M.

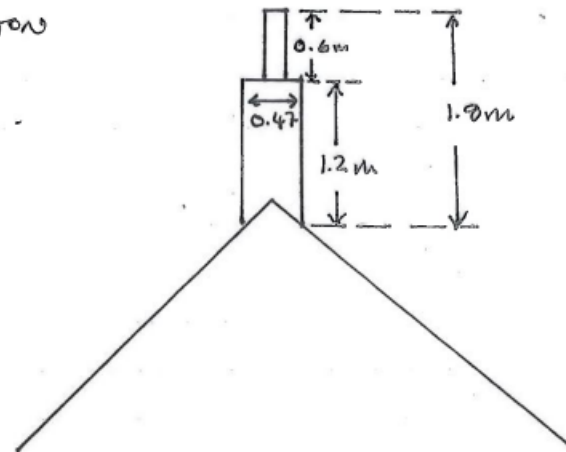

SIDE ELEVATION (1:50 SCALE) SHOWING NEW HEIGHT OF CHIMNEY BRICKWORK (SAME POT) IN LIKE FOR LIKE BRICKS + MORTAR TO ACHIEVE REQUIRED 1.8 m TOP OF POT TO THATCH. NO OTHER DIMENSIONS ALTERED.

Planning Balance

Approval

Material considerations

Refusal

Material considerations

- Proposal will not cause harm to the character of the Histon Conservation Area
- Proposal will not cause harm to the historic fabric or character of the listed building



- None

Officer Recommendation: Approve